

## IDENTIFICATION AND MONITORING OF INSTABILITY IN FINANCIAL SYSTEMS

*Bogdan Włodarczyk<sup>1</sup>, Marek Szturo<sup>2</sup>*

<sup>1</sup> Department of Macroeconomics

Faculty of Economics

University of Warmia and Mazury in Olsztyn

e-mail: bogdan.wlodarczyk@uwm.edu.pl

<sup>2</sup> Department of Finance and Banking

Faculty of Economics

University of Warmia and Mazury in Olsztyn

e-mail: marsz@uwm.edu.pl

Key words: financial system, financial instability, systems engineering.

### Abstract

Financial instability is often the result of a positive feedback loop, which is an inseparable element of the functioning of the financial system. The task dealing with identification, modeling and analyzing the causes and effects of such feedback loops requires assuming a systems' engineering perspective, which is rarely taken into consideration when designing remedial solutions. The aim of the study was to evaluate how it is possible to identify and monitor the susceptibility of a financial system to potential threats. The popular method of data modeling known as signed directed graphs (SDG) was used. The method is able to pick up information which is not taken into account by a traditional network model of the financial system. It provides essential information about the direction of impact and control between the nodes. Thanks to this technique, it is possible to analyze the potential instability spots of the system.

### IDENTYFIKACJA I MONITORING NIESTABILNOŚCI SYSTEMU FINANSOWEGO

*Bogdan Włodarczyk<sup>1</sup>, Marek Szturo<sup>2</sup>*

<sup>1</sup> Katedra Makroekonomii

Wydział Nauk Ekonomicznych

Uniwersytet Warmińsko-Mazurski w Olsztynie

<sup>2</sup> Katedra Finansów i Bankowości

Wydział Nauk Ekonomicznych

Uniwersytet Warmińsko-Mazurski w Olsztynie

Słowa kluczowe: system finansowy, niestabilność finansowa, inżynieria systemowa.

## Abstrakt

Niestabilność finansowa często wynika z pętli dodatniego sprzężenia zwrotnego, które jest nieodłącznym elementem funkcjonowania systemu finansowego. Zadanie polegające na identyfikacji, modelowaniu i analizowaniu przyczyn i skutków takich pętli sprzężeń zwrotnych wymaga przyjęcia perspektywy inżynierii systemów, które rzadko jest uwzględniane podczas projektowania rozwiązań sanacyjnych. Celem badania była ocena możliwości identyfikacji i monitoringu podatności systemu finansowego na potencjalne zagrożenia. Wykorzystano popularną metodę modelowania danych, określaną jako etykietowane grafy skierowane (*signed directed graphs* – SDG). Metoda ta jest w stanie wychwycić informacje, które są nieuwzględniane przez tradycyjne modele sieciowe systemu finansowego. Dostarcza istotnej informacji o kierunku wpływu i kontroli między węzłami. Dzięki temu możliwe jest analizowanie potencjalnych punktów niestabilności systemu.

## Introduction

Modern financial systems are characterized by a complex set of interdependencies among a great number of institutions. Tensions in one part of the system can quickly spread to other parts of the system, which is currently constituting a critical mechanism of the formation of threats for the stability of the entire financial system. Therefore, there is a need to understand the fundamental structures and dynamics of the financial system. One of the conclusions drawn by market regulators from the crisis of 2008 is the conviction that the quality of mutual connections between institutions constitutes the key to the identification of threats (CAPIGA 2010).

Financial instability results from positive feedback loops inherent to the processes and phenomena happening in the financial system. More precisely, the instability comes from uncontrolled responses to market shocks that enhance and expand the effect of the primary shock (SOLARZ 2010).

Moreover, actions taken by a single institution at the moment of danger in order to diminish the influence of the systemic risk, may become a source of positive feedback, which destabilizes the other institutions owing to the interactions that take place. Such actions may be described as a local stabilization reached at the expense of global destabilization. It is best reflected by the phenomenon of a bank run, when the thrifty mass behavior of customers trying to avoid risk by withdrawing their deposits results in accelerated destabilization and the bankruptcy of a bank. In other words, a prolonged queue in front of a bank causes a growing incentive for other people to join it, which means the strengthening of a feedback loop which results in the bankruptcy of the bank.

Of particular importance for the stability of the financial system in Poland is maintaining the stability of the banking sector, whose assets account for two thirds of the total financial system. Banks play a key role in financing the economy and monetary settlements (OSIŃSKI 2016).

The problem of the bank run in its classical form has been notably limited due to the deposit guarantee; however, similar dynamic processes take place in the entire financial system. For instance, when a bank experiences restrictions to the access of liquid funds, the reaction of its board may be limited lending towards hedge funds. As a result, hedge funds, actively managing their own risk, close positions outstripping specified classes of financial assets. This chain of actions, reasonable from every market participant's point of view, becomes the cause of global instability. It leads to a fall in asset prices, which lowers the value of securities. This, in turn, increases the bank's problem of access to liquid funds and accelerates the sale of assets by hedge funds, who are forced to supplement the margins. Similar phenomena or schemes are called fire sales (SHLEIFER, VISHNY 2011).

The understanding of these key phenomena that take place in the financial system requires the skill of identifying such feedback in the global functioning of institutions in the financial system. For this reason, one should precisely get to know the channels of information transmission and control mechanisms used by various financial institutions. A further complication is the fact that the character of the feedback that is occurring is based on the scale of the process. Small changes in the price of assets, funds or the financial situation of a bank are easily absorbed by the system; however, large-scale price shocks may induce a disastrous domino effect.

The aim of this article was to evaluate how it is possible to identify and monitor the susceptibility of a financial system to potential threats. Using directional graphs for this purpose would result in the possibility of establishing automated warning systems identifying potential threats through regular testing of crisis scenarios.

### **Graph theory, systems engineering and the identification of threats to the financial system**

Financial stability analysis needs to cover all of the above sources of risks and vulnerabilities. This requires systematic monitoring of individual parts of the financial system and the real economy (house-holds, firms, the public sector). The analysis must also take into account cross-sector and cross-border linkages, because imbalances are often caused by a combination of weaknesses from different sources (SCHINASI 2005).

In order to understand the effect of feedback in the financial system, labeled directed graphs were used. It is a tool used in systems engineering to specify the mechanisms of the processes which take place. Using the directed graph allows observers to capture the flow of information, the environmental

conditions and the relations which underlie the feedback. With its help, one may picture the supervisory rules and the ways of reacting to threats used by individual participants in the system. It facilitates the regular observation of the interactions happening and the recognition of positive feedback loops, which are difficult to observe. In this way, one may define the areas of potential instability (GAI, KAPADIA 2010).

Directed graphs may serve to highlight the information overlooked by traditional network models referring to the interactions inside the financial system. Traditionally, the amount of liabilities and flows are the most frequently described, which is useful to define the value and complexity of relations between the financial institutions (ALLEN, BABUS 2009).

Usually the financial institutions are described in such schemes as having nodes, with the flows between them known as edges (lines). Most frequently, they are used to define which network scheme will ensure the reliability of the financial system structures. In traditional network models, the flow of information and responses to the information are often not included. Due to this, it is difficult to use these models to explain how the information pulses, and how the supervision over a great number of subjects shapes the interactions inside the system.

The key criterion for engineering these systems within systems is designing their safety and stability. However, the financial system is a self-organizing system. Individual financial institutions have their own procedures of risk management which allows them to remain stable, whereas the system itself as a whole has never been designed in terms of stability and safety. For this reason, it is necessary to understand the configurations generating positive and negative feedback and learn the alternative flow paths between funds, institutions and financial instruments in case of shocks. In a more general view, it is important to know how the interactions between institutions shape the system's susceptibility to threats and, consequently, how these threats contribute to its instability (*Systemic failures: Challenges...* 2011).

In this article, graph theory and systems engineering were presented to manage the systematic risk, and in particular to monitor the dynamic phenomena such as the forced sale of assets or a bank run. In these cases, unique interactions take place, during which the locally stabilizing activities contribute to global instability. Feedback means there is an influence of the output on the input. When we deal with the subtraction of the output from the input, it is defined as negative feedback. It has the effect of stabilizing the relation. In the case of adding the output to the input, it is defined as positive feedback which results in the destabilization of the relation. An example of negative feedback may be the following economic interaction: an increase in prices leads to an increase in the supply of goods (in the directed graph it is marked as a solid

line, the change progresses in the same direction, i.e. an increase triggers an increase), then the increase in the supply of goods leads to a drop in prices (in the directed graph it is marked as a dotted line, the feedback interaction progresses in the opposite direction, i.e. an increase triggers a decrease). The positive feedback would take place if the increase in prices caused an increase in the supply of goods, which on the other hand would cause further increases in prices (in the graph it was marked with two solid lines with opposite arrowheads).

## **Modeling the network of connections in a financial system**

One step in modeling the network of connections in the financial system would be to move away from model-consistent (“rational”) expectations. Modeling the build-up and unwinding of financial imbalances while retaining the assumption that economic agents have a full understanding of the economy is possible, but artificial. Heterogeneous and fundamentally incomplete knowledge is a core characteristic of economic processes. As we all see in our daily lives, empirical evidence is simply too fuzzy to allow agents to resolve differences of views, and this fundamental uncertainty is a key driver of economic behavior (BORIO 2012).

In drawing 1 a simplified scheme of the financial system was presented, with a banking institution (financial) as a mediator between the fund givers and fund recipients. An analogy was used for presenting the processes in production systems, defining the streams at the system;s entrance and exit. Bank customers are investors, hedge and pension funds and other banks. Inside the banking institution, there are unique business units which are responsible for providing funds and financial instruments for the needs of the products offered to the customers.

In Figure 1 the activity of the banking institution was simplified to two types of processes:

- borrowing funds and securities – bank uses the sources for funds (money market) and securities (eg. pension funds);
- providing liquidity to the market as a market-maker – the bank carries out transactions in the market of financial instruments in order to occupy the position in securities on which the demand is reported by bank customers; it also includes securitization, which requires transformation of liquidity and risk.

Within service selling, the bank offers loans for hedge funds in order to purchase securities. With the use of a financing platform, the bank decides on strategies to acquire external funds using safe securities as protection.

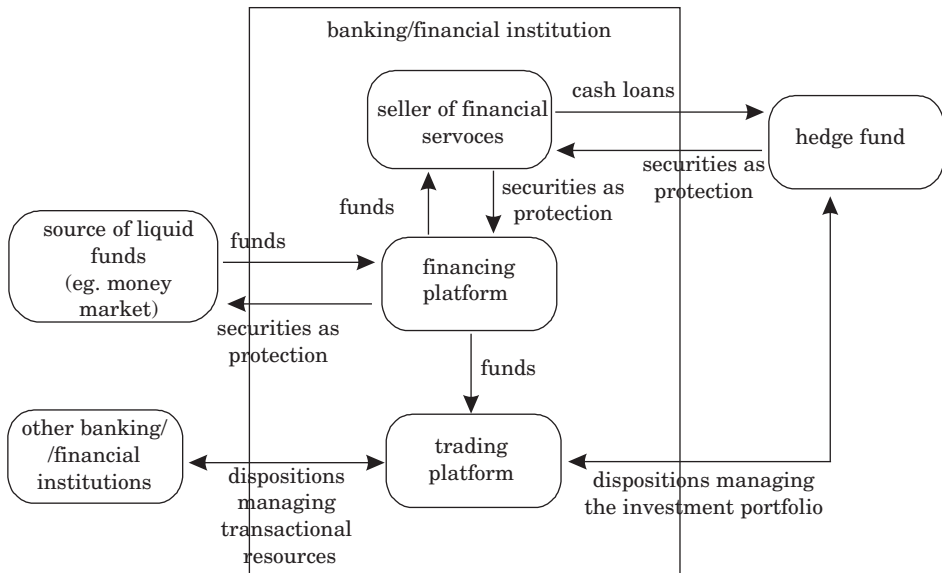

Fig. 1. Flow scheme in a simplified model of the financial system

Source: own study.

The bank's trading platform manages the resources (investment portfolio) through transactions in financial markets, which are the funds accumulated by the financing platform.

The bank interacts with the suppliers of liquid funds (the money market) who the money market funds belong to. With other banks, the interactions are carried out through the OTC (over the counter) market. The last subject category are the hedge funds which use the technical services offered by banks (prime brokerage) to implement long and short positions in the market. In this case they represent a bigger group of institutional customers, which include asset management companies, pension funds, wealth management companies and insurers.

Owing to the interactions between the components of a banking institution, various types of transformations are formed. The financing platform raises short-term loans in the money market and the money obtained in that way is offered as loans of longer term to customers with lower creditworthiness. In that way, the transformation of deadlines and risk is made. The trading platform keeps the securities until it is not able to protect them, neither based on customer demand nor on the open market (liquidity transformation).

The network of interdependences being created around a banking institution is even more complicated. Institutional customers (eg. hedge funds) may act in a dual role, as both buyer and seller of financial instruments.

In Figure 2 the same institutional layout was presented, however the labeled directed graph was used for this purpose. The difference is in embracing the cause and effect relationships.

For simplification, the existence of one type of financial asset (shares) was adopted. Its price is defined by the RB1 node, whereas its level is simultaneously being shaped and is shaping the other components of the system. The volume of securities designed for turnover, which are stock by the bank;s trading platform, is marked as PT3 and in the case of hedge funds as HF3. Both hedge funds (HF) and trading platforms (PT) need cash provisioning in order to finance the owned securities (assets). The fund provider in this case is the money market (RN), the seller of financial services (SUF) and the financing platform (PF).

In each case, the accessibility to financing depends on a given unit;s possibilities of protection (HF or PT), whereas the protection is in the form of securities (financial assets). The changes in the market price of securities leads to a change in the value of protection, which, on the other hand, translates into the funds' availability. The level of brokerage fee for the loan for buying the securities and the margin of profit (SUF3, RP1) influence the relations of the available loan funds (SUF2, RP3) and the value of protection (SUF1, RP2). The level of leverage (HF2, PT4) influences the relation of borrowed funds (HF1, PT1) and the volume of transactional securities (HF3, PT3) in the case of hedge funds and trading platforms.

In particular, the hedge fund is shaped by the value of loans (HF1), based on their availability from the seller of financial services (SUF1) as well as being based on the comparison between the supply of owned securities (HF3) and the accepted level of leverage (HF2).

The loan action of the seller of financial services (SUF2) is determined by the ability to finance the financing platform (PF2) and the brokerage fee from the loans raised for the purchase of securities (SUF3).

The trading platform functions as a market maker, and is able to handle transactions for every amount of securities ordered by a hedge fund. However, under certain conditions it may mean a significant increase in the volume of shares designed for turnover (PT3). When the border point of the leverage (PT2) set by the level of available funds of the financing platform (PF2) is crossed, the control mechanism is activated, and it consists of an excessive flow of securities into the market ( $PT1 = PT4 - PT2$ ), which on the other hand makes the prices of assets drop (RB1). The control mechanism of the trading platform that is a market maker is different from its equivalent in the hedge fund. The trading platform depends on the financing platform in financing securities. Decreasing the inflow of funds (lowering the border point of the leverage at PT2) can make the trading platform get rid of a part of securities in the banking market.

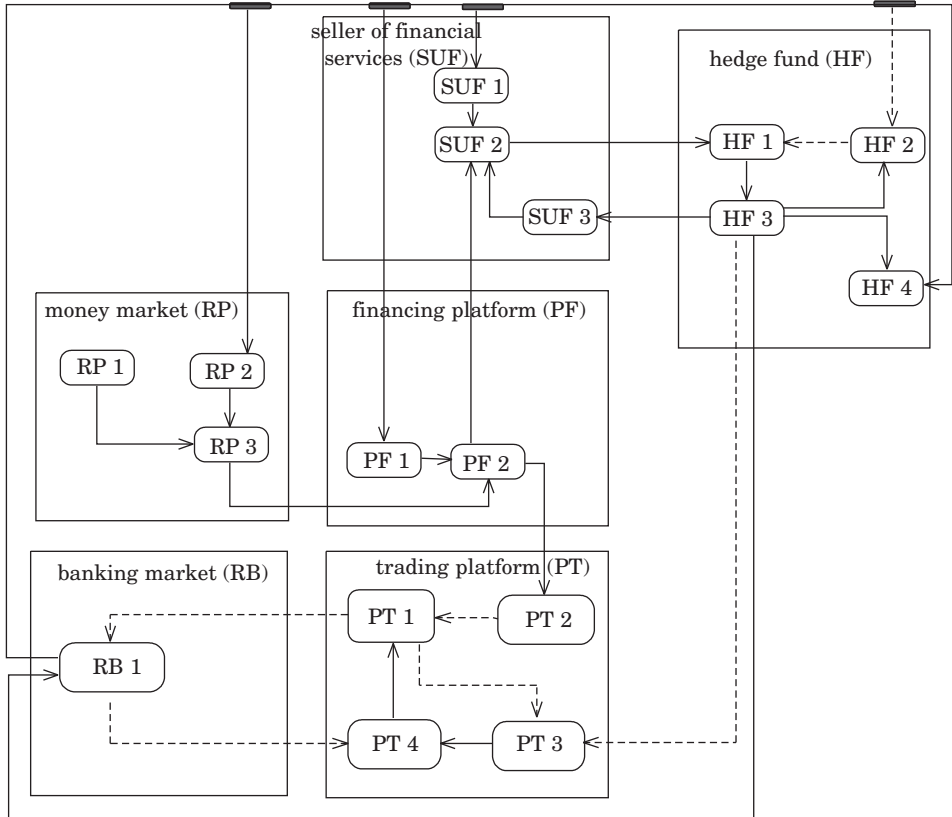

Fig. 2. Directed graph illustrating a simplified model of the financial system  
Source: own study.

The money market provides funds for the trading platform and hedge fund through the financing platform. Changes in the availability of funds for the financing platform result in a change in the amount of securities held by the trading platform and hedge fund, which leads to a price change of the financial assets as a consequence.

The whole system is controlled by the price level of the assets in the banking market. In turn, it is determined by the activity of the trading platform and the hedge fund. The prices of assets are shaping the value of protection, which translates to the brokers' tendency to provide funds.

The directed graph defines the reasons why in the financial system, financial crises appear one after another. Almost all the paths shown in drawing 2 constitute positive feedback. In such a configuration, the shock referring to one node produces positive feedback and can spread to the others. Not all positive feedback is important, due to the fact that the directed graph



defines the direction of spreading, but does not refer to the intensity of these changes.

A single node is the effect of the influence of various effects, and the final net effect depends on the range of the positive feedback loop. In Table 1 a list of types of feedback (known as feedbacks) for the presented directed graph was shown. The positive feedback loop Mia takes place when the result of multiplying the signs placed on the feedback path is positive. Whereas when it is negative, we deal with the negative feedback loop.

Table 1  
Comparison of feedbacks in the analyzed systemic model

No.	Positive/negative	Feedback loop
1	positive	RB1, RP2, RP3, PF2, SUF2, HF1, HF3, PT3, PT4, PT1, RB1
2	positive	RB1, PF1, PF2, SUF2, HF1, HF3, PT3, PT4, PT1, RB1
3	positive	RB1, RP2, RP3, PF2, SUF2, HF1, HF3, RB1
4	positive	RB1, HF2, HF1, HF3, PT3, PT4, PT1, RB1
5	positive	RB1, PF1, PF2, SUF2, HF1, HF3, RB1
6	positive	RB1, HF2, HF1, HF3, RB1
7	positive	RB1, SUF1, SUF2, HF1, HF3, PT3, PT4, PT1, RB1
8	positive	RB1, SUF1, SUF2, HF1, HF3, RB1
9	positive	RB1, PF1, PF2, PT2, PT1, RB1
10	positive	RB1, RP2, RP3, PF2, PT2, PT1, RB1
11	positive	SUF3, SUF2, HF1, HF3, SUF3
12	negative	PT1, PT3, PT4, PT1
13	positive	RB1, PT4, PT1, RB1
14	negative	HF2, HF1, HF3, HF2

Source: own study.

Only the feedbacks number 12 and 14 are negative. They are a reflection of the internal systems of risk management for a bank’s hedge fund and trading platform. The parameter controlling the size of engagement in securities is the level of leverage. However, building these internal controlling loops in bigger loops between the institutions leads to the creation of positive feedbacks which constitute a potential threat for the financial system.

In Table 2, positive feedback loops connected with the sudden sale of securities (a fire sale) are presented. It appears when the disruption of a system occurs that will cause the closing of the position by a hedge fund. This disruption may occur in three ways: a price drop, which leads to the fall of the value of assets, an increase of the fee taken by the seller of financial services for the loans on shares, which leads to bearing additional costs, or a decrease in the possibility of giving loans on shares by the seller of services.

Table 2

Comparison of feedbacks in the analyzed systemic model

Sale of financial assets		
6	positive feedback	RB1, HF2, HF1, HF3, RB1
4	positive feedback	RB1, HF2, HF1, HF3, PT3, PT4, PT1, RB1
Bank run		
3	positive feedback	RB1, RP2, RP3, PF2, SUF2, HF1, HF3, RB1
10	positive feedback	RB1, RP2, RP3, PF2, PT2, PT1, RB1

Source: own study.

The first of the loops (No 6) presented in the table indicates the increase of leverage (HF2) induced by the price shock (RB1). The hedge fund reduces its positions then, which results in a further price drop. The second loop (No 4) has the same mechanism (price drop, leverage increase, closing positions), but it covers the range of the bank's trading platform. The amount of securities sold by the hedge fund (HF3) increases the stock of securities held by the trading platform (PT3), which causes an increase of the leverage (PT4). Later, the trading platform sells out the securities (PT1) with the aim of decreasing the leverage, which in consequence leads to a further price drop (RB1).

It is worth noticing that every unit attempts to maintain its stability. The seller of financial services keeps the level of creditworthiness (SUF2) within the limits defined by the value of protection (SUF1). The hedge fund determines the referential level of leverages (HF2) in order to control its risk, while the trading platform manages the deposit of securities (PT3) by selling out the excess of securities (as market-maker) at the moment the optimal size of the assets owned is exceeded (PT2, PT1). Despite these activities, global instability is not neutralized. It shows a fundamental feature of the financial system, meaning that global instability of the system is possible even when its individual components are attempting to limit their own risk.

Another manifestation of this system instability is a bank run (table 2). It usually begins as a result of the disruption of a bank's provisioning flow in liquid funds coming from the money market. It may be caused by the growth of uncertainty about the quality of protection (securities), a drop in the value of protection (RP2) or by a change in profit margins carried out at the trading market (RP1), this results from diminishing trust.

Diminishing of cash flow (RP3) influences the drop of possibilities to handle the transaction of securities through the trading platform (PF2, PT2), which translates into selling the excess of securities on the market (PT1). The dynamics of the phenomenon happens in such a way that the forced sale lowers the prices of assets, which, on the other hand, causes a decrease in the value of

protection, limiting further provisioning from the money market. The first loop referred to as a bank run (No 3 in table 2) continues the course of dependencies in the direction of a substantial reduction of the possibilities of financing the hedge (SUF2, HF1), which leads to closing the positions (HF3) and lowering the prices of RB1. In loop nr 10 the influence of the mechanism of diminished provisioning of funds available for the trading platform (PF2, PT2) was shown, which decreases the stock of owned securities owing to their selling out (PT1) and leads to a further price drop (RB1).

All the dependences above constitute scenarios from a group of possibilities. Taking into consideration that real processes are much more complicated, one should be aware of how difficult it is to identify and monitor the instability of a financial system.

## **Conclusion**

The process of organizing system processes in the financial system is independent. This means that it is possible to design a financial system in detail taking into account its stability as the main aim of the interactions taking place. Because of this, it seems vital to identify the feedback loops which form inside the system and may result in its instability. It also helps to define the previously unknown possibilities of cash and securities flow, which may be activated in case of price shocks.

It was determined that system engineering provides useful tools in the form of directed graphs. The presented simplified model of the financial system, due to the use of directed graphs, revealed additional analytical possibilities, with the goal of identifying and monitoring the system instabilities.

Based on examples of such phenomena as the selling out of financial assets or a bank run, the possibilities of the formation of positive feedback were highlighted, which are a source of danger. It was proven that even the existence of internal systems of risk management inside an institution does not prevent the global instability of the system. Quite the opposite situation may occur where in some cases of highly intense dynamic processes taking place, these processes increase the instability and lead to a system crash. Due to this fact, it has become important to understand the broad implications of the solutions introduced to limit the risk, as well as to understand the mechanisms of feedback which contribute to the formation of instability.

## References

- BORIO C. 2012. *The financial cycle and macroeconomics: What have we learnt?* BIS Working Papers, 395.
- CAPIGA M. 2010. *Determinanty i struktura bezpieczeństwa finansowego*. In: *Sieć bezpieczeństwa finansowego*. Eds. M. Capiga, W. Gradoń, G. Szustak. CeDeWu, Warszawa.
- FRANKLIN A., BABUS A. 2009. *Networks in Finance*. In: *The Network Challenge: Strategy, Profit, and Risk in an Interlinked World*. Eds. P.R. Kleindorfer, Y. Wind, R.E. Gunther.
- GAI P., KAPADIA S. 2010. *Contagion in financial networks*. Proceedings of the Royal Society A: Mathematical, Physical and Engineering Science, 466: 2401–2423.
- OSIŃSKI J. 2016. *Raport o stabilności systemu finansowego*. NBP, Warszawa.
- SCHINASI J.G. 2005. *Preserving Financial Stability*. Economic Issues, 36.
- SHLEIFER A., VISHNY R.W. 2011. *Fire Sales in Finance and Macroeconomics*. Journal of Economic Perspectives 25(1): 29–48.
- SOLARZ J.K. 2010. *Istota i sposób pomiaru ryzyka systemu finansowego*. In: *Ryzyko w finansach i bankowości*. Eds. B. Filipiak, M. Dylewski. Difin, Warszawa.
- Systemic failures: Challenges and opportunities in risk management in complex systems*. 2011. Venkatasubramanian Venkat, AIChE Journal, 57(1): 2–9.